

STQ SERIES
FOUR SHAFT

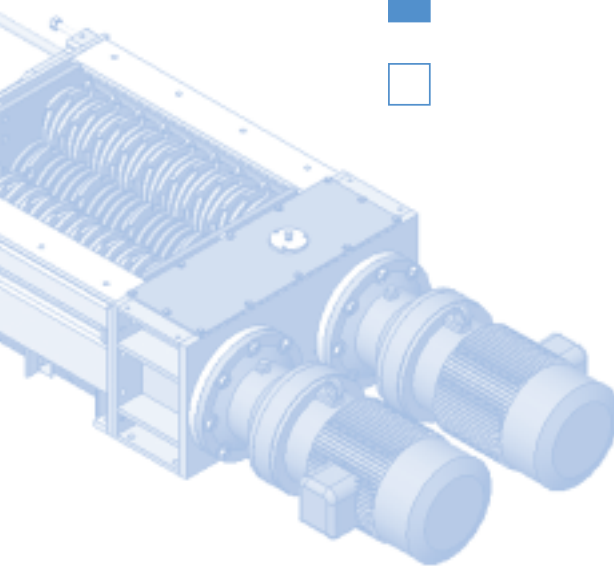

TECHNICAL SPECIFICATIONS

Shredder	STQ-50	STQ-75	STQ-100	
Drive	Electric	Electric	Electric	
Number of Motors	Two	Two	Two	
Power Range	hp	50	60 80	150
Voltage	208 - 600	208 - 600	208 - 600	
Cycle	50/60	50/60	50/60	
Number of Cutting Shafts	4	4	4	
Shaft Speeds	rpm	24/33	13/19 18/27	20/31
Screen Size	in	0.8 - 2.0	0.8 - 2.8	1.0 - 3.3
Cutting Chamber Width	in	28	35.3	40.9
Cutting Chamber Lengths	in	29.1/38.8/48.4	38.8/48.4/58.1	47.2/59
M/C Weight (lb) approx Shredder Only	6200 - 7600	13600 - 15600	17100 - 18700	

All dimensions are in inches unless noted otherwise

SHRED-TECH | FOUR SHAFT INDUSTRIAL SHREDDERS



Uniform particle size in a single pass.



SHRED-TECH

WORLD LEADER IN REDUCTION ENGINEERING AND MANUFACTURING

STQ SERIES



SHRED-TECH

www.shred-tech.com e shred@shred-tech.com

t 1 800 465 3214 f 519 621 4288

world leaders.

world leaders.

All Shred-Tech Shredders are available under US Federal Supply Contract. © All rights reserved. Shred-Tech and Shred-Tech logo are registered trade-marks of Shred-Tech.

STQ SERIES



CIRCUIT BOARD REDUCTION

ELECTRONIC HARDWARE DESTRUCTION

REDUCTION OF STEEL DRUMS

MAGNESIUM REDUCTION

WIRE & CABLE REDUCTION

PAPER SHREDDING

TIRE PROCESSING

The Shred-Tech STQ Series Four Shaft Shredders are designed to process bulk materials; including wood, plastics, paper, tires, textiles, electronic equipment, medical waste, organic waste and manufactured products to a uniformed particle size in a single pass.

Heavy-duty construction based around Shred-Tech's standard torsion tube body concept ensures robust trouble free operation. Shred-Tech's proprietary triple seal cutting chamber, abrasion resistant wear components and exceptionally high knife tip cutting force ensure low noise and vibration, reduced wear, and decreased maintenance costs.

Shred-Tech's standard durable hex shafts and robust drive systems are at the heart of the STQ line of shredders ensuring years of reliable service. Engineers have focused a high degree of attention on building a line of four shaft shredders that are maintenance friendly and allow for quick and easy change out of components.



-
-
-
-

Shred-Tech's team of experienced technical sales representatives are trained to advise on the exact equipment specifications needed to meet all application requirements. Complete testing



facilities with modern video and digital imaging hardware are also available to ensure Shred-Tech's equipment recommendations are based on factual data and available for customers to review.

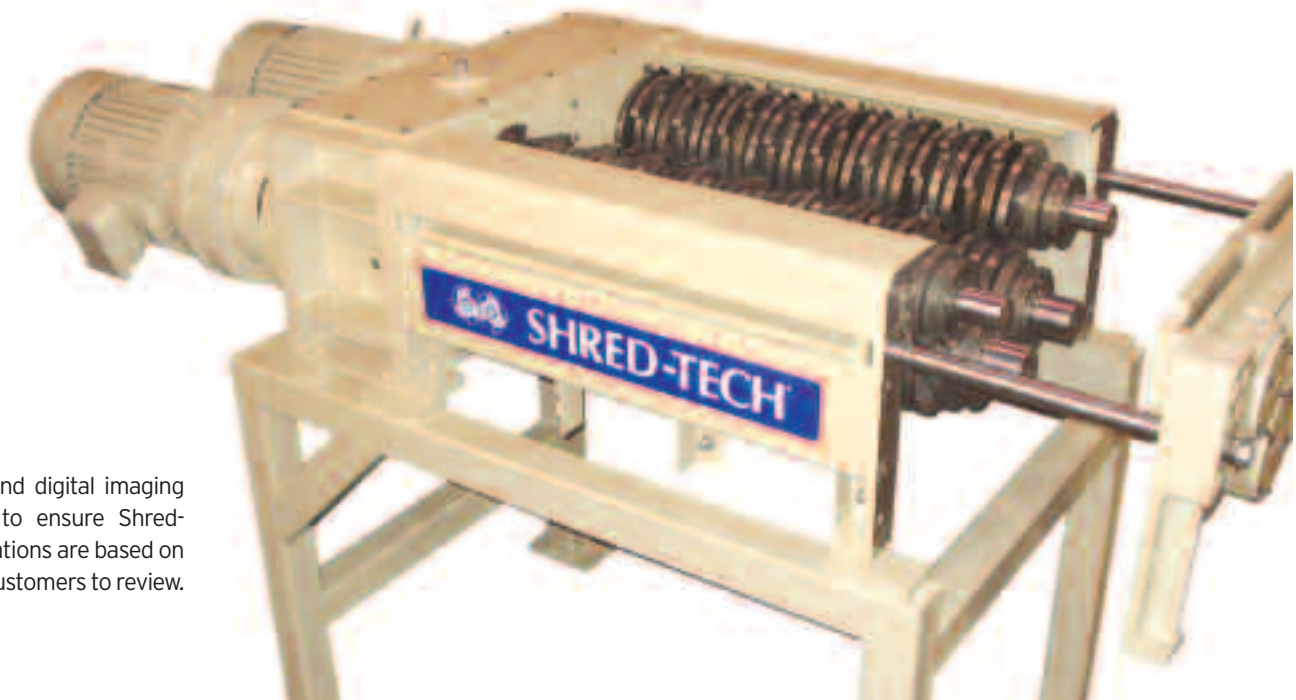

Simplified modular construction reduces the number of major components and increases parts commonality; thus reducing spare parts requirements. Rollout screens are easily removed from the end of the shredder. This allows for quick and easy screen cleaning and efficient change out of alternative screen sizes. The proprietary sealed bearing assembly is also removed from the end of the shredder ensuring easy cutting chamber service and long bearing life.

Interchangeable screen sizes allow for maximum flexibility when determining desired particle size. STQ models range from 50 hp (37.5 kw) up to 150 hp (112 kw) and are available in a wide variety of cutting chamber sizes to meet the demands of various materials in all possible shapes, sizes and material loading methods.

As with all Shred-Tech shredders, the STQ line can be equipped with a full complement of options, including:

- Custom hoppers and stands
- In-feed and discharge conveyors
- Pneumatic and hydraulic ram hoppers.
- Vibrating, magnetic or rotary separation
- Modem capabilities
- PLC interfacing for peripheral equipment
- Pneumatic discharge and dust extraction

FEATURES

BENEFITS

- Rollout screens are easily removed from the end of the shredder.
- Abrasion resistant wear components help to decrease operating costs.

FEATURES

BENEFITS

- Sealed bearing assembly is removed with the cutting chamber end plate for easy cutting chamber service and long bearing life.
- Heavy-duty torsion tube body construction ensures robust trouble-free operation.